

GENESYS 824R **INSTALLERS MANUAL**

Contents

INSTALLER PROGRAMMING

How to Enter and Move Around Within Installers Program Mode	p. 1
Custom Zone Programming, Location 00-46	p. 1
Communications Programming, Location 48-56C	p. 3
Entry/Exit Delays, Output Cutoffs, Location 57-58C	p. 5
PGM Output Options, Location 59-59A	p. 5
Misc. Reporting Codes, Location 60-72C	p. 6
Expanders, Keypads and Partitions, Location 73-73C	p. 7
Signal Routing, Location 75-75C	p. 8
System Features, Location 76-79C	p. 8

WIRING INSTRUCTIONS

Instruction & Diagram	p. 10
-----------------------	-------

PROGRAMMING SUMMARY & INSTALLATION HINTS

To install additional Keypad	p. 13
To make partitioning	p. 13
To install Hard wire expander	p. 13
To install Long range radio	p. 13
To default the control panel	p. 13
Bus Test	p. 14
PGM output	p. 14
Auxiliary Power Information	p. 17
Hexadecimal Conversion Chart	p. 18

INSTALLER PROGRAMMING

HOW TO ENTER PROGRAM MODE

The Installers PIN is required to access the Installers program. The **Installers PIN is Preset from the factory as [9999]** and may be changed in Location 78. Care must be taken when changing Installers PIN.

To enter Program Mode:

Depress [**Installer PIN**] + [**↑**] + [**7**]. The LCD should now display the abbreviation (PRG.).



You are now in program mode.

MOVING WITHIN INSTALLERS PROGRAM MODE

Once within the Installers program mode, movement is achieved by selecting specific Memory Locations and going to those locations. Each Memory Location is identified with a two-digit number. Entering that number at the (PRG.) prompt will advance you to that specific location and display any memory within that field.

To access a Sub-Location (example, 56B), enter the two digit location number and press the [**↑**] button until the appropriate sub-location is displayed. To move back to a previous Sub Location within that memory location, press [STAY].

Once within the field, changes can be made by either:

A) Entering the appropriate two digit number or,

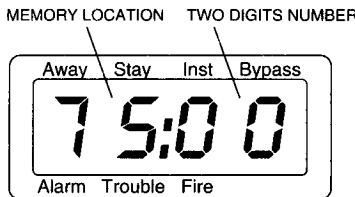

B) toggling on or off status indicators located along the top and bottom of the display.

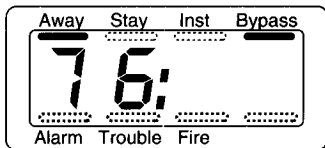

Example: Depressing the [1] button will cause the "AWAY" LCD to turn on or off. And pressing the [4] button will cause the "BYPASS" LCD to turn on or off.

When the desired changes are made, simply depress the [**↑**] button to lock the information in the EE prom and advance to the next memory field.

To exit a specific Program Location, press the [#] button. This will exit you back to the (PRG.) prompt.

When all changes have been completed, depress the [#] button twice to exit out of the Installer Program mode.

Memory Location 00 - 46 CUSTOM ZONE PROGRAMMING

All of the GENESYS 824 zones can be custom programmed to perform any number of specific functions. For each zone you will be making several decisions about the functions it will perform. The choices are as follows.

ZONE TYPE * Check Programming Sheet for Defaults. The first two-digit entry defines the **Zone Type** as well as the **Loop Type**.

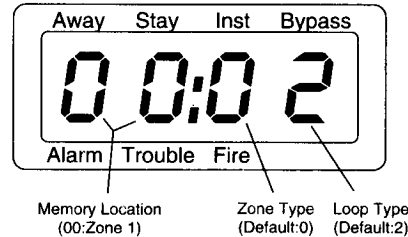

Zone type is the first digit entry. The zone types and the value to enter are:

- 0 - ENTRY - EXIT 1
- 1 - ENTRY - EXIT 2
- 2 - PERIMETER INST
- 3 - INTERIOR 1
- 4 - INTERIOR 2
- 5 - INTERIOR 3
- 6 - 24 HOUR
- 7 - FIRE 24 HOUR
- 8 - DAY CIRCUIT

0 - ENTRY - EXIT 1 is used for an Entry/Exit zone where a delay is required to Enter or Exit the premises.

1 - ENTRY - EXIT 2 should be used on entry exit zones requiring longer periods of time, such as garage doors, gates, outdoor detectors, etc.

2 - PERIMETER INSTANT is used for devices that should create an instant alarm when the system is armed in any mode.

3-4-5 - INTERIOR 1 - 2 - 3 is used for devices such as PIR, ultrasonics, mats, etc. that are used inside the premises.

6 - 24 HOUR is used for devices that will activate an alarm condition whether the panel is armed or disarmed.

7 - FIRE ZONES are used for devices such as smoke detectors (4 wire), heat sensor, water flow, etc. that need to be active 24 hours.

8 - DAY CIRCUIT is used for devices such as window foil, screens, etc. In a disarmed state, an activation creates a trouble (trbl) condition, in an armed state, an activation creates an alarm.

ARMING MODE	ENTRY/EXIT 1 and 2	PERIMETER INSTANT	INTERIOR #1	INTERIOR #2	INTERIOR #3
AWAY	Delayed Exit Delayed Ent	Delayed Exit Instant	Delayed Exit Follower or Instant	Delayed Exit Follower or Instant	Delayed
STAY	Delayed Exit Delayed Ent	Delayed Exit Instant	Delayed Exit Follower or Instant	Bypassed	Delayed
INSTANT	Instant Always	Instant Always	Instant Always	Bypassed	Delayed

LOOP TYPE is the second digit entry. The loop type and value entered are:

- 0 - Normally Open
- 1 - Normally Closed
- * 2 - Normally Open - Normally Closed
- * 3 - N.O. - supervised w/EOL - reports trouble on break, alarm on short
- * 4 - N.C. - supervised w/EOL - reports trouble on short, alarm on open

* NOTE: EOL resistor 2.2k ohm 1/2 watt
OPTEX Morse Part #1401-4649.

ITEM A - Loop Response - Adjusted in two digit increments in a multiplier of 50 ms. A longer loop response may be required for devices such as water flow detectors. A shorter loop response may be required for devices such as glass break detectors. Value: 00 - 99 x 50 ms., Default 05 (250 ms.).

ITEM B - Alarm Code - (2 Digit Entry) When the zone creates an alarm condition the panel will transmit this code. Value: 01 - FF, Default 00 (disabled).

ITEM C - Trouble Code - (2 Digit Entry) If the zone is programmed for a Loop Type three or four and that zone goes into a trouble condition, this is the code that is transmitted. Value: 01 - FF, Default 00 Disables, Default 00 (disabled).

ITEM D - Bypass Code - (2 Digit Entry) If the zone is programmed for bypass allowed (see Item G) this code will be transmitted when the zone is bypassed and the system is armed. Value: 01 - FF, Default 00 (disabled).

* **NOTE:** BYPASS SHOULD NOT BE ALLOWED ON FIRE CIRCUITS.

ITEM E - Restore Code (2 Digit Entry) A Restore Code is a common function that is transmitted either after an alarm condition or after a trouble (trbl) condition (if programmed as loop type three or four). Value: 01 - FF, Default: 00 (disabled).

ITEM F - Zone Features - (Multiple Entries) If the bar is present, the function is active. If the bar is not present that function is inactive. To turn on or off the function, depress the number that corresponds to that keypad indicator:

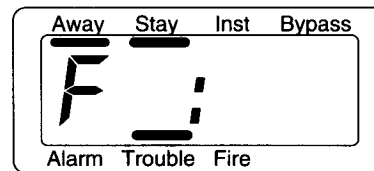

(Shows Default condition)

- 1 - **AWAY** = Telephone Output
- 2 - **STAY** = Audible
- 3 - **INST** = Pulse Bell
- 4 - **BYPASS** = PGM 1
- 5 - **ALARM** = PGM 2
- 6 - **TRBL** = Walk Test
- 7 - **FIRE** = Monitor
- 8 - **BLANK** = Silent Day - Audible Armed

1 - TELEPHONE OUTPUT - is required to be active to transmit all zone reporting codes. If the codes are programmed and this function is not active, the zone report codes will not transmit. Default: YES

2 - AUDIBLE - is required to be active to energize the steady bell voltage output. If this function is not active the zone will be silent. See Item 58 for cutoff times. Default: YES

3 - PULSE BELL - is required to be active to energize the pulsing bell voltage output. Audible must be enabled to energize this function. Default: NO

4 - PGM OUTPUT 1 - is an open collector that sinks to ground for the amount of time that is programmed under Item 58. When this output is turned on as an alarm output, it can not be used for any other function. See Item 58 for cutoff times. Default: NO

5 - PGM OUTPUT 2 - is an open collector that sinks to ground for the amount of time that is programmed under Item 58. When this output is turned on as an alarm output, it can not be used for any other function. See Item 58 for cutoff times. Default: NO

6 - WALK TEST - is a function that can be used by the installer or the user. With this function active all zones will be scrolling on the LCD. When a zone is violated, the zone number will be removed from the LCD. When all zones have been tripped the LCD will display "NONE". Default: YES

NOTE: 24 Hour, Day Zone and Fire Zones are still active in this walk test mode.

7 - MONITOR - This is where the zone(s) is programmed to give a local annunciation of a violation when the system is in the monitor mode. See Item 76-B for output assignment for this feature. Default: NO.

NOTE: 24 Hour, Day Zone and Fire Zones are active in this mode.

8 - SILENT DAY - AUDIBLE NIGHT - to be used with 24 hour zones that must be programmed as audible. When the 24 hour zone(s) is violated in a disarmed state, the zone will enunciate on the LCD display, PGM 1 and/or PGM 2 will energized for the amount of time programmed if programmed as a zone output and the bell voltage will not energize. If this zone(s) is violated in an armed state, PGM 1 and/or PGM 2 will energize, if programmed as zone outputs and the bell voltage will energize for the amount of time programmed. Default: NO.

ITEM G This is a continuation of zone features and also requires multiple entries indicated by turning on or off, a bar underneath or above a keypad indicator. If the bar is present, that function is active. If the bar is not present that function is inactive. To turn the function on or off, depress the number that corresponds to that keypad indicator:

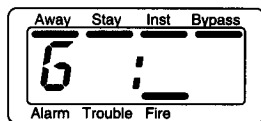

- 1 - **AWAY** = KEYPAD 1 AUDIBLE
- 2 - **STAY** = KEYPAD 2 AUDIBLE
- 3 - **INST** = KEYPAD 3 AUDIBLE
- 4 - **BYPASS** = KEYPAD 4 AUDIBLE
- 5 - **ALARM** = DISPLAY ARMED
- 6 - **TROUBLE** = SHUNT ALLOWED
- 7 - **FIRE** = BYPASS ALLOWED
- 8 - **BLANK** = RADIO OUTPUT

KEYPAD 1 - 2 - 3 - 4 - A function that enables or disables the keypad buzzer on entry. This function is only active for Entry - Exit 1 or 2 type zones. Default: YES.

DISPLAY ARMED - When a burglary type zone is violated in an armed state, the zone will be displayed on the LCD, with this function on. If more than one zone is violated, they will scroll on the LCD in numerical sequence. Default: NO.

INHIBIT MULTIPLE CODE TRANSMISSION - Used in conjunction with audible set on for the zone. When this option is used it prevents multiple code transmissions from a swinging alarm condition. Regardless of the number of trips, the panel will inhibit additional signals, from this zone, until the bell times out. It will then be ready to transmit subsequent events. Default: NO.

BYPASS ALLOWED - Allows the subscriber to manually bypass the zone if this option is set on. Default YES.

NOTE: This option should not be used on Fire zone.

Once you have completed programming memory location OO-G, the keypad will automatically advance you to memory location 02 which is Zone 2. Continue programming information in the same manner as Zone 1 (memory location 00).

To exit back or review what was programmed in Zone 1 (memory location 00) depress [#]. The LCD will display PRG. Then depress 00. To advance thru each memory location depress [↑].

Memory Location 48 - 56C COMMUNICATIONS PROGRAMMING

48 Receiver Telephone Number 1 (Panel will dial first)

The panel dials to this memory location first. Each memory location, from 48-48G, requires a 2 digit entry. Beginning with Memory location 48 enter in a dial pause (c) by depressing [AWAY] 2 and then the first digit of the telephone number and [↑]. Continue until the number is completely entered. Fill in the remaining memory location with (F) [AWAY] 5. (See Memory Location 75)

The maximum number of entries is sixteen, including dial pause and dial tone detects.

For installations that require an access code to get an outside line it's recommended to put a pause before and after the access code. Example: C-9-C-3675951.

- A = [AWAY] 0 - *
- B = [AWAY] 1 - #
- C = [AWAY] 2 - 3 Second Pause
- D = [AWAY] 3 - Dial Tone Detect

Value 0 - 9 A - D

Default FF

50 Receiver Telephone Number 2

Programmed in the same manner as Receiver number 1. This receiver output can be used as back up or redundant dialing. See memory location 75 for your options. Value 0 - 9 A - D, Default FF.

52 Account Number 1 and 2 (2 Digit Entry)

When a reporting function is activated this account number(s) will identify the subscriber to the central station. In memory location 52 will be the first two digits of the account number 52A will be the last two digits of the first account number. 52B will be the first two digits of the second account number. 52C will be the last two digits. Value 0000 - FFFF, Defaults 0000.

Hex digits can be used in accounts numbers:

[AWAY] + 0 = A
[AWAY] + 1 = B
[AWAY] + 2 = C
[AWAY] + 3 = D
[AWAY] + 4 = E
[AWAY] + 5 = F

53 Receiver Formats for Receiver 1 and 2 (2 Digit Entry)

The first digit selects a format for Receiver number one. The second digit selects a format for Receiver number two.

0 = SIA
1 = 10 PPS 4-1
2 = 10 PPS 4-1 extended
3 = 10 PPS 4-2
4 = 20 PPS 4-1
5 = 20 PPS 4-1 extended
6 = 20 PPS 4-2

0 - SIA

All reporting codes are present in the control panel software. The reporting capabilities are enabled when any reporting code other than 00 are programmed in. 00 disables the reporting capabilities for any zone when a zone(s) is violated. The information sent is determined by the type of activation:

EXAMPLES:

All Interior / Perimeter = Burglary Zone Number
Fire zones = Fire Zone Number
24 Hour = Burglary Zone Number
Zone Restore (if used) = Restore Zone Number

1 10 PPS 4-1

This is a 10 pulse per second reporting scheme. This format requires a four digit account number with a single digit event code.

In the event that you have been assigned a three digit account number, the first digit in memory location 52 must be a zero.

Example: Account 123, program 0123.

The reporting codes in this format must be single digit, therefore you must enter a zero in the first memory location followed by the code number to be transmitted.

Example: code 3, program 03.

2 10 PPS 4-1 Extended

This is also a pulse per second format that gives more reporting capabilities than 4-1 formats. The reporting digits require a two digit entry.

3 10 PPS 4-2

A pulse per second (PPS) format that is similar in reporting as 4-1 EXT. with the exception that the reporting is sent as a single round of information.

4 - 20 PPS 4-1

5 - 20 PPS 4-1 Extended

6 - 20 PPS 4-2

These are identical to 10 PPS formats except they are faster in the way that they transmitted the communication information, using 20 pulse per second.

Value 0 - 6, Default 1 - 1

53 A Anti-Jam Time

The amount of time required for the telephone company to disconnect the phone line after the panel has hung up after the first dialing attempt. Check with your phone company for this value of time. Value 00 - 99 seconds, Default 15 seconds.

53 B Line Type / Dial Attempts (2 Digit Entry)

The first digit indicates the telephone line type for dialing the central station. A zero selects Rotary (pulse) dialing while any digit 1 - 9 will select tone dialing.

Value 0 = Rotary; 1-9 = Touch-tone, Default = 0 (Rotary).

The second digit selects the number of dialing attempts to report an event to the central station. If the communicator does not receive an "ACKNOWLEDGE" from the receiver it will hang up and redial until the "ACK" is heard or the maximum number of attempts is reached.

Value 0 - 9, Default 5. (minimum for UL 864)

53 C Delay Before Dial (2 Digit Entry)

This function enables the capability of aborting the alarm transmission if the panel is disarmed within the period of time programmed in this memory location. This function is active on burglary zones only. All 24 Hour type zones will send their data immediately. Value 00 - 99 seconds, Default 00 seconds.

54 (A thru G) Download Telephone Number (Up to a 16 Digit Telephone Number)

This is a security function that when a call is initiated from a Central Station download P.C. the panel will answer, recognize the carrier tone from the modem, hang up the call, and call the P.C. back. Value 0 - D, Default FF.

56 Local Download PIN (4 Digit Entry)

This function works in conjunction with Download Telephone Number (see Memory Location 54 A-G). The telephone number must be programmed for this function to operate. When this 4 digit number + [↑] is depressed the panel will call the phone number programmed in memory location 54 A-G. Value 0 - 9, Default 0000.

NOTE: [RPGM] should be displayed when remote down load has been activated.

56 B Download - Number of Rings (2 Digit Entry)

When a call is initiated from the P.C. the panel will answer the call on this number of rings. Value 00 - 99, Default 12.

56 C Download - caller-id (telephone company option) compatibility

Where this feature is in service, the telephone company transmits the callers telephone number between the first and second ring at the premises.

For the G-824 to be compatible with this service the line seizure circuitry does not become active until after the second ring.

NOTE:

1. When this option is enabled, If on-premises telephone is taken off hook prior to the second ring the panel will not seize the line even if carrier is present at the time.

2. When this option is disabled, the line seizure circuitry will become active upon the first ring. In this case the panel will seize the line, if carrier is present, when an on-premises telephone is taken off hook before the second ring.

1 - AWAY	= Disable caller-id feature
2 - STAY	= Not Used
3 - INST	= Not Used
4 - BYPASS	= Not Used
5 - ALARM	= Not Used
6 - TROUBLE	= Not Used
7 - FIRE	= Not Used
8 - BLANK	= Not Used

Memory Location 57 - 58C ENTRY/EXIT DELAYS, OUTPUT CUTOFFS

57 Entry Delay #1 (2 Digit Entry)

This memory location works in conjunction with Entry - Exit 1 Zone Type (see Zone Types). The value programmed in this memory location will allow a delay on entry when the system is armed in the AWAY or STAY arming modes.

Values 00 - 99 seconds, Default 45 seconds.

57 A Entry Delay #2 (2 Digit Entry)

This memory location works in the same fashion as Entry Delay #1 with the exception that this value is applied to Entry - Exit 2. Value 00 - 99 seconds, Default 45 seconds.

57 B Exit Delay #1 (2 Digit Entry)

This memory location works in conjunction with a zone type programmed as Entry Exit Zone 1 (see zone type). The value programmed in this memory location will allow a delay on exit when the system is armed in AWAY or STAY modes.

Value 00 - 99 seconds, Default 60 seconds.

57 C Exit Delay #2 (2 Digit Entry)

This memory location works in the same fashion as Exit Delay #1 with the exception that this value is applied to Entry - Exit 2. Value 00 - 99 seconds, Default 60 seconds.

A separate entry exit delay period maybe selected for each partition by programming a zone(s) for Entry Exit 1 to a partition and zone(s) for Entry Exit 2 for the other Partition. A partition may have more than one entry exit zone.

58 Pre alarm Delay (2 Digit Entry)

This function silences all keypad entry warning tones for the amount of time programmed. This value adds on to the

entrance delay value. Example: 30 second pre alarm delay + 60 entrance delay - total entry time = 90 seconds. Value 00 - 99 seconds, Default 00.

☞ This option delay's all keypads with partition enabled.

58 A Bell Cutoff (2 Digit Entry)

After an alarm circuit trips and it's programmed to energize the bell voltage, the voltage will be present at terminals 28 (+) and 27 (-) for the amount of time programmed in this memory location.

Value 00 - 99 minutes, Default 10 minutes.

NOTE: A value of 00 keeps this output energized until a valid PIN is entered.

58 B PGM 1 Cutoff (2 Digit Entry)

After an alarm circuit trips and if it's programmed to energize the PGM 1 output, it will stay energized for the amount of time programmed in this memory location. Value 00 - 99 minutes, Default 0 minutes.

58 C PGM 2 Cutoff (2 Digit Entry)

After an alarm circuit trips and if it's programmed to energize the PGM 2 output, it will stay energized for the amount of time programmed in this memory location. Value 00 - 99 minutes, Default 0 minutes.

NOTE: A value of 00 will keep PGM 1 and PGM 2 output energized until a valid PIN is entered.

Memory Location 59 & 59A PGM OUTPUT OPTION

59 PGM 1 Output Option (2 Digit Entry) PGM 1 Output can be programmed to be used as **one** of the following functions:

00 - Alarm Output - used in conjunction with Zone Output. This must be programmed when used with Zone Alarm Output. Output value follows time in location 58 B.

01 - System Status - if this option is selected, PGM 1 output will be present when all zones are secured. If a zone(s) is in a non-secure state this output will not be present. When the system has been armed this output will not be present.

02 - Ground Start - used for a reporting system where a ground is required on the phone system to bring up dial tone. This output will be present for 2 seconds. (A additional relay is required)

03 - Fail to Communicate - used when the control panel has exhausted its dialing attempts that is programmed in memory location 53 B. After the last dial attempt, this output will be present.

04 - Follow Entry - Exit Delay - if this option is selected, this output will be present for the amount of time programmed in entry exit delay times (see memory location 57).

05 - PGM 1 Output with Utility PIN - when this option is selected you must also program the utility PIN in the user program in memory location 2. When the utility PIN is activated this output will be present for five seconds.

06 - Long Range Radio Output -When this option is selected, the audio data signal for radio transmission is presented at this output.

Value 00 - 99 Default 99 (disabled)
07-99 disables this output

59 A PGM 2 Output Option (2 Digit Entry) PGM 2 Output can be programmed to be used as **one** of the following functions:

00 - Alarm Output - used in conjunction with Zone Output. Output value follows time in location 58 B.

01 - System Armed Status - when this option is selected, this output will be present when the exit time has expired and will remain until the system is disarmed.

02 - Not Used - for future use.

03 - Fail to Communicate - used when the control panel has exhausted its dialing attempts that is programmed in memory location 53 B. After the last dial attempt, this output will be present until communication is restored.

04 - Follow Entry - Exit Delay - if this option is selected, this output will be present for the amount of time programmed in entry exit delay times (see memory location 57).

05 - PGM 2 Output with Utility PIN - when this option is selected you must also program the utility PIN in the user program in memory location 2. When the utility PIN is activated this output will be present for five seconds.

06 - Radio key output for Long Range Radio.
When this output is selected, it activates the radio transmitter

07 - Ring Back - When this option is selected this output will be activated for two seconds after the Open and Close report has been acknowledged. (See memory location 60)

Value 00 - 99 Default 99 (disabled)
08-99 disables this output

Memory Location 60 - 72C MISCELLANEOUS REPORTING CODES

60 - 63 - User Open Code (2 Digit Entry)
When this function is enabled this code will be transmitted when the system is disarmed. The system can transmit sixteen individual open codes. Normally the first digit entered identifies the event in this case open code followed by the user number. Example: 20 = Open Code, 1 = User #1. Program for User #1 - 21.

When using this reporting scheme the central station must be able to receive either a 3-1 extended or 4-2 format.

When using a 3-1 or 4-1 format a 2 digit entry is still required. The second digit entered is the code that will be transmitted on disarming the system. Example: 01 Code programmed. Code 1 will be transmitted, the 0 will not be transmitted. Value 01 - FF, Default 00 (disabled).

64 - 67 - User Close Code (2 Digit Entry)
When this function is enabled, this report code will be transmitted to the Central Station when the system is armed. The system can transmit sixteen individual user close codes. Normally the first digit entered identifies the event in this case the close and the second digit identifies the user number. Example: 30 = Close Code, 1 = User #1. Program for User #1 = 31.

When using this reporting scheme the central station must be able to accept either a 4-1 extended or 4-2 format.

When using a 4-1 format a 2 digit entry is still required. The second digit entered is the code that will be transmitted on arming the system. Example: 02 Programmed. Code 2 will be transmitted, the 0 will not be transmitted. Value 01 - FF, Default 00 (disabled).

68 Auto Arm Report Code (2 Digit Entry)
When the panel is programmed with the auto arm function enabled (see users program, memory location 4) this code will be transmitted to the central station if the panel has successfully performed an auto arm. If a zone is left violated the system will not perform an auto arm. Value 01 - FF, Default 00 (disabled).

68 A Fail to Auto Arm Report Code - (2 Digit Entry)
When the panel is programmed with the auto arm function enabled (see user program memory location 4) this code will be transmitted if the panel cannot perform an auto arm. Value 01 - FF, Default 00 (disabled).

68 B Duress Report Code - (2 Digit Entry).
When the duress PIN (see Memory location 78B) is entered, whether on arming or disarming, this report code will be transmitted to the central station. Value 01 - FF, Default 00 (disabled).

68 C AC Fail Report Code - (2 Digit Entry).
See Battery Calculations - Page 16

69 AC Restoral Report Code - (2 Digit Entry).
This code will report 3 minutes after AC is restored.

69 A Low Battery Report Code - (2 Digit Entry).
See Battery Calculations - Page 16

69 B Battery Restore Report Code - (2 Digit Entry).
See Battery Calculations - Page 16

69 C Box Tamper Report Code (2 Digit Entry)
When this report code is entered and the box tamper function is enabled (see memory location 76A) this report code will be transmitted to the central station when the cabinet tamper is violated. Value 01 - FF, Default 00 (disabled).

70 Box Tamper Restore Report Code (2 Digit Entry)
When the cabinet tamper is reset, this code will be transmitted to the central station. Value 01 - FF, Default 00 (disabled).

70 A Bell Fault Report Code (2 Digit Entry)
This code is transmitted when a break occurs in the bell circuit. (the end of line resistor 2.2 ohm must be installed at the bell.)
When using the G-FM (Required for UL fire) this code will be transmitted if the bell fuse is open or when a break or short is detected in the bell circuit.

70 B Auxiliary Power Fault Report Code (2 Digit Entry)

The panel has supervision of the auxiliary power fuse. If the fuse is blown this code will be transmitted to the central station. Value 01 - FF, Default 00 (disabled).

70 C Keypad Fire Report Code (2 Digit Entry)

If the keypad fire function has been enabled (see memory location 76A) this code will be sent to the central station when "STAY" and "6" are pressed simultaneously for approximately 2 seconds when the buttons are released, this code will be sent. Value 01 - FF, Default 00 (disabled).

71 Keypad Emergency Report Code

Same as above except depress "INSTANT" AND "9".

71 A Keypad Panic Report Code - Same as 70C, except depress "AWAY" and "3".

71 B Open Restore Report Code - (2 Digit Entry)

After an alarm condition has been created this report code will be transmitted when the system has been disarmed. Value 01 - FF, Default 00 (disabled).

71 C 2 Wire Smoke Detector Loop Report Code - (2 Digit Entry)

When 2 wire smokes, wired to terminals 26 and 25 initiate an alarm condition, this report code will be transmitted to the central station. Value 01 - FF, Default 00 (disabled).

72 - Fire Trouble Report Code (2 Digit Entry)

When a trouble is detected on the 2 wire smoke detector loop, this report code will be transmitted to the central station. Value 01 - FF, Default 00 (disabled).

72 A Fire Restore Code - (2 Digit Entry)

This reporting function is a common restore code for both Fire Alarm and Fire Trouble on the 2 wire smoke detector circuit. After a fire alarm or Fire Trouble has been cleared, this report code will be transmitted to the central station. Value 01 - FF, Default 00 (disabled).

72 B Bell Restore Code - (2 Digit Entry)

After an alarm condition has been created this report code will be transmitted when the bell shuts down and the zone has been secured. If the bell shuts down and the circuit (zone) has not been secured, the code will not be transmitted until the zone is secured. Value 01 - FF, Default 00 (disabled).

72 C Ground Fault Report Code - (2 Digit Entry)

This report works in conjunction with the G-FM. When the supervised earth ground is lost on the G-FM this report code will be transmitted to the central station. Value 01 - FF, Default 00 (disabled).

**Memory Location 73 - 73C
EXPANDERS, KEYPADS AND PARTITIONS**

73 Expander Zone Definition (2 Digit Entry)

This location determines which type of Expander Boards are installed and how many of each are installed. The choices are as follows:

- 00 - No zone expansion board on bus
- 01 - Board 1 installed & unit is hardwire expansion.
- 02 - Board 1 & 2 installed and both are hardwire zone expansion.
- 03 - Not Used / Future Use
- 04 - Not Used / Future Use
- 05 - Not Used / Future Use
- 06 - Not Used / Future Use
- 07 - Not Used / Future Use
- Default (00) No Expansion Board

If you have selected this option without installing the expander boards the keypad will indicate a Bus Trouble and transmit a Bus Fault report code (see memory location 73B). Value 01 - 02, Default 00 (disabled).

73 A Keypad Installed/Partitions A memory location that requires multiple entries indicated by turning on or turning off a bar underneath or above a keypad indicator. If the bar is present that function is active. If the bar is not present that function is inactive. To turn on or off the function depress the number that corresponds to that keypad indicator:

1 AWAY	KEYPAD 1	Always ON
2 STAY	KEYPAD 2	
3 INST	KEYPAD 3	
4 BYPASS	KEYPAD 4	
5 ALARM	KEYPAD 1	for partition 1
6 TRBL	KEYPAD 2	for Partition 1
7 FIRE	KEYPAD 3	for Partition 1
8 BLANK	KEYPAD 4	for Partition 1

One thru four are enabling the number of keypads that are going to be used.

Five thru eight are assigning the keypads to a partition. If the bar is turned on over an indicator that keypad will be assigned to partition number one. If the bar is turned off, that keypad will be assigned to partition number two (see memory location 76A).

73 B Buss Fault Report Code (2 Digit Entry)

If a fault is detected on the buss, this report code will be transmitted to the central station. Value 01 - FF, Default 00 (disabled).

73 C Charge Time - High & Low (2 Digit Entry)

Add total current draw of system including control panel, keypad(s) and auxiliary devices. Use table below to get digits for location 73C.

TOTAL SYSTEM CURRENT (mA)	DIGIT TO ENTER IN LOCATION 73C
00-100 mA	91
101-200 mA	92
201-300 mA	93
301-400 mA	94
401-500 mA	95
501-600 mA	96
601-700 mA	97
701-800 mA	98
801-900 mA	99

**Memory Location 75 - 75C
SIGNAL ROUTING**

75 Receiver Reporting for Alarm & Restores - Open & Close (2 Digit Entry)

The first digit tells the panel which receiver or receivers to direct the alarm and restore report codes.

Value 0 - 4, Default 0.

Value	Function
0	Report only to receiver number 1
1	Report only to receiver number 2
2	Report first to receiver number 1, if not successful, attempt to report to receiver number 2
3-4	Report to both receiver number 1 and receiver number 2

The second digit tells the panel which receiver or receivers to direct the open and close report code to. Value 0 - 4, Default 0.

Value	Function
0	Report only to receiver number 1
1	Report only to receiver number 2
2	Report first to receiver number 1, if not successful, attempt to report to receiver number 2
3	Report to both receiver number 1 and receiver number 2
4	No reporting for Receiver 1 or 2

75 A System Report Code (2 Digit Entry)

The first digit tells the panel which receiver or receivers to direct the housekeeping signals (power codes, failure codes, etc.). Value 0 - 9, Default 0.

Value	Function
0	Report only to receiver number 1
1	Report only to receiver number 2
2	Report first to receiver number 1, if not successful, attempt to report to receiver number 2
3	Report to both receiver number 1 and receiver number 2
4	No Telco reporting for System messages

Value 0 - 4 Default 0

The second digit selects reporting of codes on Long-range radio.

Value	Function
0	No radio out put for open/close, system test, or system messages
1	open/close on radio
2	system test code on radio
3	open/close + system test codes on radio
4	system messages on radio
5	system message + open/close on radio
6	system message + system test on radio
7	system message + system test + open/close on radio

Value 0 - 7 Default 0

75 B Communication Fail Report Code (2 Digit Entry)

The Communication Fail report Code is transmitted when the panel has exhausted its dialing attempts (see memory location 53B). Or when TLM fault is detected. Value 01 - FF, Default 00 (disabled).

☞ Must use "Two phone lines" or "One phone line and Long range radio".

75 C Number of Radio Attempts

The number of times the event is transmitted.
Value 00 - 09 units

**Memory Location 76 - 79C
SYSTEM FEATURES**

76 System Features (Multiple Entries)

Indicated by turning off a bar above or underneath a keypad indicator. If the bar is present that function is active. If the bar is not present, that function is inactive. To turn on or off the function, depress the number that corresponds to that keypad indicator.



1 AWAY	Bell Test
2 STAY	Bell Audible on Bus Fault
3 INST	Digital first & Radio second
4 BYPASS	G-FM Installed
5 ALARM	50 Hz
6 TROUBLE	Telephone Fault(TLm) Monitoring enable
7 FIRE	System test to be reported on Telco
8 BLANK	Partition System

1 - Bell Test - with this option selected, whenever the system is armed, the bell voltage will be present for three seconds. Default NO

2 - Bell Audible on Bus Fault - with this option selected bell voltage will be present for the amount of time programmed in memory location 58A or when a valid PIN is entered in the keypad. Default NO

3 - Digital first & Radio second - with this option selected the digital signal will be transmitted first, if it is successful, the radio signal will not be sent.
Default NO

4 - G-FM Installed - with this option selected the panel will recognize the G-FM (Fire Module) installed in the installation and will indicate a buss fault if the G-FM fails. Default NO

5 - 50 Hz or 60 Hz - If the bar is not present unit will be set for 60 Hz. Default 60 Hz

6 - Telco Fault Monitoring Enable - with this option selected, the keypad will give a visual indication of a telephone trouble (TLM) and emit a pulsing audible tone from Keypad. Default NO

7 - System Test to be Reported on Telco - with this option selected the panel will automatically transmit the signal to the central station on the telco line.

8 - Partition System - with this option selected the panel can be used as two separate systems. The first half of the zones will automatically become partition number 1 and the second half of the zones will become partition number 2. PIN's one thru eight automatically become assigned to partition number one and PIN's nine thru sixteen will become assigned to partition number two. Partition number one will always report its information to Receiver number one and partition number two will always report its information to receiver number two. (See memory location 48 thru 53.) Default NO

76 A System Features (Multiple Entries)

If the bar is present the function is active. If the bar is not present this function is inactive. To turn on or off the function depress the number that corresponds to the keypad indicator.

- 1 **AWAY** Keypad Panic Enabled
- 2 **STAY** Keypad Panic Audible
- 3 **INST** Keypad Fire Enabled
- 4 **BYPASS** Keypad Fire Audible
- 5 **ALARM** Keypad Emergency Enabled
- 6 **TROUBLE** Keypad Emergency Audible
- 7 **FIRE** Key switch or Tamper Inputs
- 8 **BLANK** AC fail Audible on Keypad

Keypad Panic Enabled - with this option selected the keypad panic function is enabled. The panic buttons are "AWAY" and "3". Pressing both buttons simultaneously will activate an alarm code if programmed (see memory location 71A). Default NO

Keypad Panic Audible - with this option selected the keypad panic button, "AWAY" and "3", will energize the bell voltage for the amount of time programmed in memory location 58A. Default NO

Keypad Fire Enabled - same as Panic, except "STAY" and "6". Default NO

Keypad Fire Audible - same as Panic, except "STAY" and "6". Default NO

Keypad Emergency Enable - same as Panic, except depress "INSTANT" and "9".

Keypad Emergency Audible - same as Panic, except depress "INSTANT" and "9". Default NO.

Key switch or Tamper Inputs - when the key switch option is selected terminals 7 and 10 will support any momentary arming station. To select the key switch input option the bar must be displayed above the Fire indicator.

To select the tamper switch, the bar shouldn't display above the Fire indicator. When selected for tamper a report code must be programmed in memory location 69C. This input will be silent only.

AC fail is audible on Keypad - If this option is selected, Keypad will make beep tone together with trouble display on LCD when AC power is failed. If not selected, only trouble display will be indicated

76 B Monitor Mode Features (Multiple Entries)

If the bar is present the function is active. If the bar is not present the function is inactive.

- 1 **AWAY** Acknowledge required for monitor mode
- 2 **STAY** Bell output for monitor mode
- 3 **INST** PGM 1 output for monitor mode
- 4 **BYPASS** PGM 2 output for monitor mode
- 5 **ALARM** Bell output for walk test mode
- 6 **TROUBLE** Bell output for TLM fault in armed condition
- 7 **FIRE** 2 wire smoke alarm verification
- 8 **BLANK** Steady Bell voltage output for two wire smoke loop

Acknowledge Required - with this option selected and if the panel has been put in the monitor mode, when a zone is violated the keypad will give a continuous audible until the [↑] key is depressed or a valid PIN is entered. The zone number will stay in the display until the zone is secured. If this option is not selected the keypad will emit a 2 second tone. The zone will continue to display until the zone is secured. Default NO

Bell Output for monitor mode - If this option is selected the bell voltage will be present momentarily if acknowledge is set to NO, continuously if acknowledge set to YES. Default NO

PGM 1 output for monitor mode same as Bell Output. Default NO

PGM 2 output for monitor mode same as Bell Output. Default NO

Bell Output for walk test mode - with this option selected Bell activates for one second when a zone is activated in the walk test.

Bell Out put for TLM fault in armed condition - with this option selected the panel will activate the bell output and emit a pulsing audible tone from keypad along with indication of [TLM fault]. If the system is configured for Radio, it generate common fail signal.

2 wire smoke alarm verification - when this feature is enabled the panel will automatically reset the power to the two wire smoke detectors upon receipt of an alarm signal. The reset time is a predetermined period in accordance with UL requirements. If the detector returns to an alarm condition, when power is re applied, the panel will initiate the appropriate reporting as programmed.

Steady Bell Voltage Output for Two Wire Smoke Loop - With this option enabled the panel will activate the steady bell voltage for the period of time programmed in memory location 58A. If this option is not selected, the bell voltage will pulsate.

77 Self Test Time Interval (Hours)

A memory location where the hours of a day the self test code will be transmitted to the central station. The value entered in this location must be 2 digits. The hours will be entered in military time. Example: 3:00 PM - Program 15. Value 00 - 23, Default 99 (disable).

77 A Self Test Time Interval (Minutes)

A memory location where the minutes of the hour the self test code will be transmitted. Example: test at 3:30 PM = 15:00 hours, 30 minutes. Value 00 - 59 minutes, Default 99.

77 B Self Test Time Interval (Days)

This memory location indicates the interval between days the panel will transmit the self test code to the central station. Value 01 - 99, Default 00 (disabled)

77 C Self Test Report Code - (2 Digit Entry)

When the self test time occurs this report code will be transmitted to the central station. Value 01 - FF, Default 00 (disabled).

78 Installers PIN (4 Digit Entry)

This memory location is **very important**. Value 0000 - 9999, Default 9999

78 A Duress PIN (4 Digit Entry)

This PIN will arm or disarm the system and will transmit the duress report code (see memory location 68B) to the central station. Value 0000 - 9999, Default FFFF.

NOTE: PIN's (installer, duress, user) cannot be duplicated. If a duplicate PIN is attempted to be programmed an audible from the keypad will indicate the PIN has been rejected.

79 - 79 A Battery Charging Calculations

BATTERY CALCULATIONS

To comply with UL requirements the primary power failure trouble signal for the communicator shall not be transmitted until the standby power capacity is at least 25 percent depleted, but not more than 50 percent. Therefore, it is necessary to program these two memory locations with the total current available (subtract total current draw of panel, keypad(s), expansion modules and other auxiliary devices powered from auxiliary power from total current capacity) and amp-hour rating of battery to be used.

79) $\frac{1000 \text{ mA} - \text{Total current in mA}}{10} = \text{XX}$

Convert XX in Hex Chart 1 and enter in 79.

79 A) $\text{AH Batt} \times 10 = \text{YY}$

Convert YY in Hex Chart 1 and enter in 79 A.

NOTE 1:

LOW BATTERY CODE is transmitted when:

- 1) there is no battery connected;
- 2) the battery fuse is open;
- 3) the battery voltage goes below approximately 11.5 VDC.

NOTE 2:

GOOD BATTERY is transmitted when the battery voltage reaches approximately 12 VDC.

79B First 2 digits of Panel Access ID for RPU (Remote Programming Utility)

79C Last 2 digits of Panel Access ID for RPU Memory Location

80 - 95 NOT USED / FUTURE USE

WIRING INSTRUCTIONS

TERMINALS

1 & 2 16 VAC Class II plug-in transformer (20 VA maximum). Use 18 ga twisted or zip pair and keep wire run as short as possible. Test the electrical outlet being used to ensure it is not controlled by a light switch. (24 hour source)

3-4-5-6 Data bus inputs - These terminals are used for wiring in keypads (maximum 4), expansion modules (maximum 2), and G-FM. The keypads and expansion modules can be wired in either a daisy chain or homerun configuration. Each keypad must be addressed by setting the two dip switches located on the back of each keypad. Maximum cable length 1,000 feet.

	KEYPAD		SWITCH	
	1	2	1	2
	1	2	on	on
	2	3	on	off
	3	4	off	on
	4		off	off

7-11-12 PGM-1 and PGM-2 outputs are open collector outputs - Terminal 7 is the positive voltage output and Terminal 11 is the negative output of PGM-1. Terminal 7 is the positive voltage output and Terminal 12 is the negative output of PGM-2. The maximum current available for these two outputs is 20 mA each. When PGM-1 and or PGM-2 are triggered, these outputs go low.

7 - 9 Auxiliary power outputs - Terminal 7 is positive voltage output and Terminal 9 is negative voltage output. These terminals provide a continuous 12 volt output. These terminals should be used for any device that doesn't require an interruption of power to reset an activation.

8 - 9 Terminals 8 is a positive, switched power output. Terminal 9 is negative.

If any zones are configured as fire zones, the power is derived from these terminals. If a fire zone is activated, the user enters his PIN and terminal 8 will go low for ten seconds.

7 - 10 Tamper N.C. or Keyswitch inputs - This input is a programmable option. See installation and programming manual - memory location 76A. When programmed as a tamper switch input the input will always be silent. When programmed as a keyswitch input, a momentary close is required. The panel will always arm in an away mode, when a keyswitch is used.

13 thru 24 Protection loops - Zones 1 thru 8 are connected to these terminals as indicated in Fig. 1.

All loops are two wire and may be wired as the following "Loop Types":

0 NORMALLY OPEN: This loop requires the use of detection devices or switches that close (short) on alarm.

1 NORMALLY CLOSED: This loop requires the use of detection devices or switches that open on alarm.

2 NORMALLY OPEN and NORMALLY CLOSED: This loop requires an end-of-line resistor (2.2 K ohms) and will accept both types of switch operation (open or closed).

3 NORMALLY OPEN with TROUBLE REPORT ON BREAK: This loop requires an end of-line resistor (2.2 K ohms) and detection devices or switches that "close" (short) on alarm. An open condition (loss of 2.2 K ohms resistor) will produce:

a) If programmed as a 24 Hour zone and for trouble report - the audible in the keypad will sound and the communicator will transmit the trouble code to the central station.

b) If programmed as a controlled zone (Day/Night) and for Trouble report - the audible in the keypad will sound if the system is disarmed.

If the system is armed the audible in the keypad will sound and the communicator will transmit the trouble code to the central station.

4 NORMALLY CLOSED with TROUBLE REPORT on SHORT: This loop requires an end of-line resistor (2.2 K ohms) and detection devices or switches that "open" on alarm. A short will produce:

a) If programmed as a 24 Hour zone and for trouble report - the audible in the keypad will sound and the communicator will transmit the trouble code to the central station.

b) If programmed as a controlled zone (Day/Night) and for Trouble report - the audible in the keypad will sound if the system is disarmed.

If the system is armed the audible in the keypad will sound and the communicator will transmit the trouble code to the central station.

25(-) 26(+) Two wire smoke detector loop. These 2 terminals are used in conjunction with ESL Model 425 , 429 series. If there is an activation on this loop entering a valid [PIN] + [↑] + [2] will reset this loop. Maximum number of ESL model 425 , 429 series smoke detectors that can be used on this loop is twenty (20).

The keypad will display [FIRE] when this input trips.

Do not use Heat detectors, Water flow switch or Any other device on this circuit.

Only the two wire smoke detector loop may be used to comply with UL846

27(-) 28(+) Bell voltage output - 12 VDC is provided on these terminals. The maximum amount of current available is 2 amps. For supervision of the bell circuit, a Fire Module (G-FM) must be used.

29 thru 32 Telephone line connection - The Genesys 824 provides for single phone line hookup with full line seizure. To expand to two line use the Fire Module (G-FM) must be used.

		<u>RJ JACK</u>	<u>PIN</u>
TERM 29	PREMISE RING	GRAY	1
TERM 30	PREMISE TIP	BROWN	8
TERM 31	TELCO RING	RED	4
TERM 32	TELCO TIP	GREEN	5



DIGITAL ALARM COMMUNICATION TRANSMITTER (DACT)
MODEL G-824

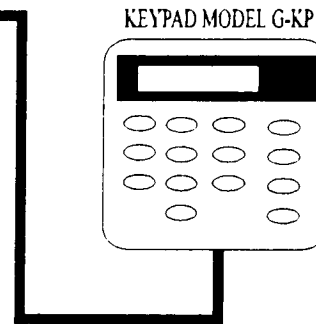
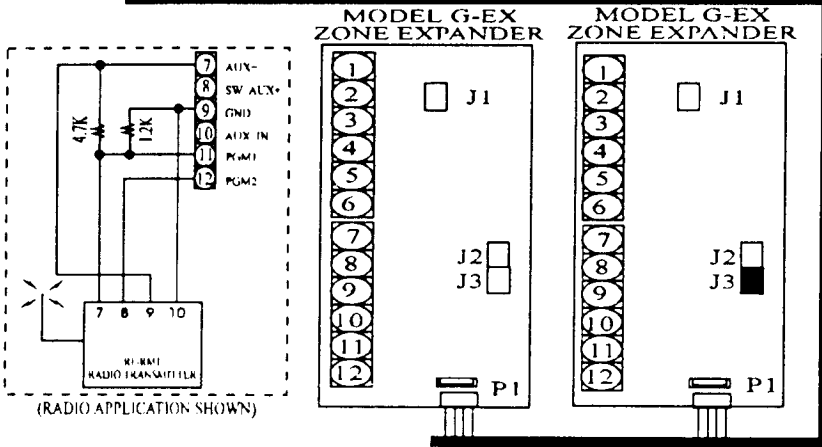
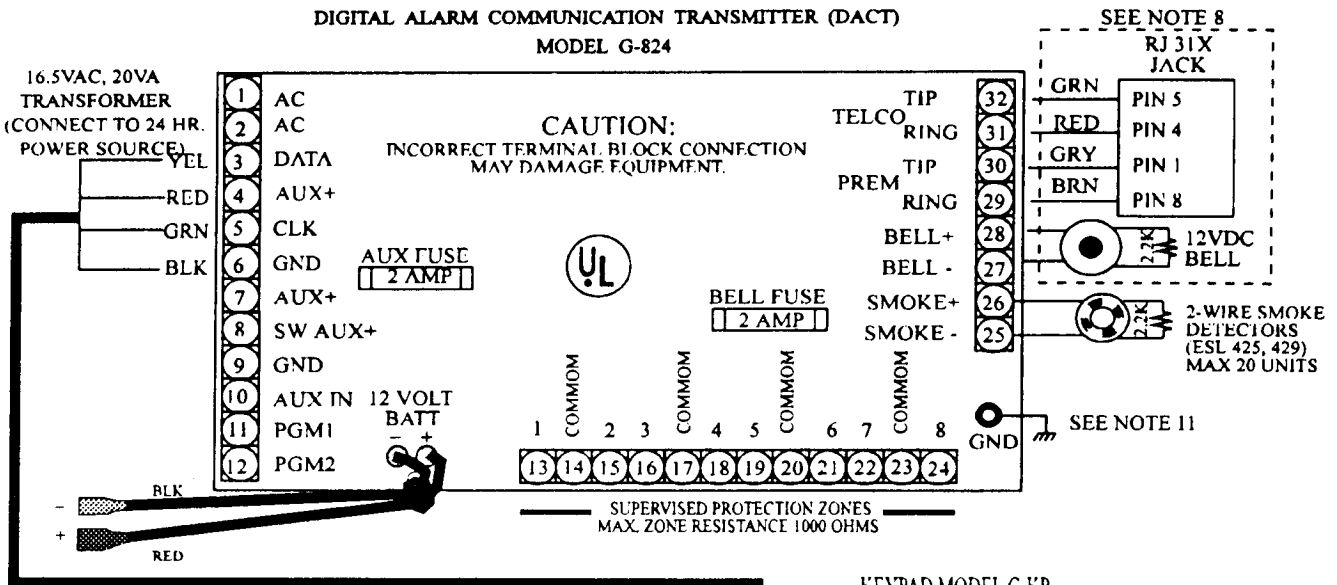

NOTE:

1. MAXIMUM COMBINED POWER AVAILABLE ON 824 CONTROL PANEL INCLUDING TERMINALS 4, 6, 7, 8, 26, 27 AND 28 IS 750 mA AT 12VDC. THIS PANEL IS POWER LIMITED.
2. USE 2.2 KOHM 1/2 WATT RESISTORS FOR ZONES THAT REQUIRE EOL (ZONE TYPE 2, 3 AND 4).
3. BELL AND 2- WIRE SMOKE ALSO REQUIRE 2.2 KOHM EOL RESISTORS.
4. THE OPERATING VOLTAGE RANGE FOR SMOKE DETECTOR TERMINALS IS 10.2 TO 15.8 VOLT.
5. ZONE EXPANDER G-EX OR G-EXC BOARD IS CONFIGURED AS ZONE 9 TO ZONE 16 WHEN JUMPER J1, J2 AND J3 ARE LEFT OPEN. THE BOARD IS CONFIGURED AS ZONE 17 TO ZONE 24 WHEN J1, J2 ARE LEFT OPEN AND J3 IS SHORTED.
6. COMMUNICATION BETWEEN CONTROL PANEL AND G-EX IS MADE THROUGH 4- WIRE CONNECTIONS AS SHOWN. CABLE ASSEMBLY IS PROVIDED.
7. PGM1 AND PGM2 ARE OPEN COLLECTOR OUTPUTS THAT GO LOW TO APPROXIMATELY 2V WHEN ACTIVATED. MAXIMUM CURRENT : 20mA.
8. BOXED AREA SHOWS PHONE AND BELL CONNECTIONS WHEN G-FM IS NOT USED. DISREGARD IF USING G-FM.
9. REFER TO BATTERY CALCULATION CHART IN INSTALLERS MANUAL(3440-0237) FOR CORRECT AMP-HOUR BATTERY CONNECTED TO G-824 WITH BATTERY HARNESS (5090-0252).
10. TERMINALS 7 AND 10 MUST BE USED FOR CABINET TAMPER FOR UL LISTED INSTALLATIONS.
11. CONNECT EARTH GROUND TO RIGHT SIDE MOUNTING SCREW.

UL FILE NO. S-1152

APPLICABLE U.L. STANDARDS

CENTRAL STATION BURGLARY ALARM CONTROL UNIT (UL 1610), POLICE CONNECT (UL 365), AND LOCAL BURGLAR ALARM SYSTEM CONTROL UNIT, (UL 609) HOUSEHOLD FIRE (UL 985) AND BURGLAR WARNING SYSTEM CONTROL UNIT (UL 1023), DIGITAL DIALER COMMUNICATOR (UL 1635).
THE G-EX MODULES MUST BE MOUNTED IN THE G-824 CCS CONTROL CABINET IN ALL INSTALLATIONS MEETING COMMERCIAL CENTRAL STATION BURGLARY ALARM SYSTEM UL611, UL1610, UL365, AND UL609.

PROGRAMMING SUMMARY AND INSTALLATION HINTS

TO INSTALL ADDITIONAL KEYPAD

1. Set dip switch on the keypad

KEYPAD	SWITCH	
	<u>1</u>	<u>2</u>
1	ON	ON
2	ON	OFF
3	OFF	ON
4	OFF	OFF

2. Program memory location **73A** in accordance with the number of keypad you installed.

TO MAKE PARTITIONING

1. Program **73A**
Select which keypad to be assigned to partitioning 1 and 2.

2. Program **76**
Enable partitioning function.

Now the first half of the zones are assigned to partition 1, and the second half of the zones are partition 2.
Also, The user [PIN] number 1 to 08 are assigned to partition 1, 09 to 16 are partition 2 automatically.

3. Program user [PIN] number 09 (or 09 to 16 as necessary) from user programming mode ([PIN] + [↑] + [8]) memory location 1. (see owners manual for the details)

Note: Zones will be divided as follows when expander board(s) is installed.

Number of expander	Zone assignment	
	<u>partition 1.</u>	<u>partition 2</u>
0	01 to 04	05 to 08
1	01 to 08	09 to 16
2	01 to 12	13 to 24

TO INSTALL HARD WIRE EXPANDER(s) (G-EX)

1. Wiring

<u>Expander</u>	<u>824 Terminal</u>
Yellow	3
Red	4
Green	5
Black	6

2. Set jumper position on the expander Board

	Jumper		
	<u>1</u>	<u>2</u>	<u>3</u>
1st board	open	open	open
2nd board	open	open	close

3. Program memory location 73
4. Program memory location 16 to 46 (custom zone programming for zone 09 to 24)

TO INSTALL LONG RANGE RADIO

1. Enable Radio output for each zone as necessary in Memory location **00G** to **46G**.
2. Memory location **59** (PGM1 output option)
Select output option 06 (Radio modulator output)
3. **59A** (PGM2 output option)
Select 06 (Radio key output)
4. **75** (Receiver reporting for ALARM/OPEN, CLOSE)
Program as required. (see page 8 for details)
5. **75A** (System report code)
Program as required. (see page 8 for details)
6. Program **75C** (Number of Radio attempt)
7. Program **76** (System features)
8. Connections

RM-1 MODULE

TERM 7 (TRANS MODULATOR)
TERM 8 (RADIO KEY)
TERM 9 (SYSTEM +)
TERM 10 (SYSTEM-)

G-824R

TERM 11 (PGM-1)
TERM 12 (PGM 2)
TERM 7 (AUX.)
TERM 9 (GROUND)

Also resistor of 1.2 K(brown, red, red) should be connected between TERM-11 & TERM-9 on G-824R.
Also resistor of 4.7 K(yellow, violet, red) should be connected between TERM-11 & TERM-7 on G-824R.

TO DEFAULT THE 824 CONTROL PANEL

1. Press [installer pin] + [↑] + [7]
2. The display will read [PRG]
3. Press [99], The display will read [TST8]
4. Press [0], Display will read [DEF]
5. Press [↑], Display will read [CODE]
6. Press [9999] then press [↑]. Wait 15 seconds.
7. The display will flash [TIME]. The panel is now defaulted.

BUS TEST

This Procedure is to determine whether keypads and or add on modules are functional. It is very helpful for trouble shooting the system for failures of hardware.

[Installer PIN] + [↑] + [7]

Keypad will display [PRG]

Press [9] [9]

Keypad will display [TST8]

Press [1]

Keypad will display [WAIT]

Wait approximately 50 seconds.

Keypad will beep and display [ERR]

Note: Do not touch keypad while beeping.

After keypad stops beeping press [↑] to view result of test.

If there is anything less than 45 should display, there is a potential problem that might occur, such as keypad or module failure indications.

Each depression of the [↑] will advance the display to the next programmed device.

the symbols for each device are;

- [B1:--] = Keypad Number 1
- [B2:--] = Keypad Number 2
- [B3:--] = Keypad Number 3
- [B4:--] = Keypad Number 4
- [B9:--] = Expander Board 1
- [BA:--] = Expander Board 2
- [BB:--] = Fire Module (G-FM)

PGM OUTPUT

The PGM output has a maximum current rating of 20mA.

If you are going to use the PGM outputs for triggering some other control or indicating devices that draw more than 20mA you must use a **RELAY MODULE**. Your local distributors carry modules such as the **ALTRONIX RBSN RELAY MODULES** and the **ALARM CONTROL CORP. MODEL 8007 RELAY MODULE WITH THE 8012 RELAY** which are low current draw relays. Maximum current on relay contacts depends on which module is used.

NOTE: After you have completed testing the systems cut one side of the resistor on the 8007 relay module board, this will allow the relay to operate at a lower voltage should the **AC POWER** fail and the battery voltage gets low. After cutting the resistor please test unit again. Please note Fig.1

Fig.1

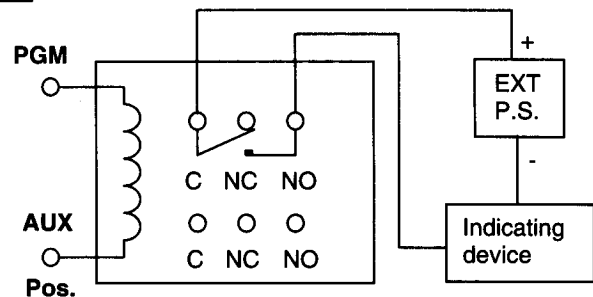

When using a PGM for **Ground Start**, use the wiring hook up shown in Fig.2

Fig.2

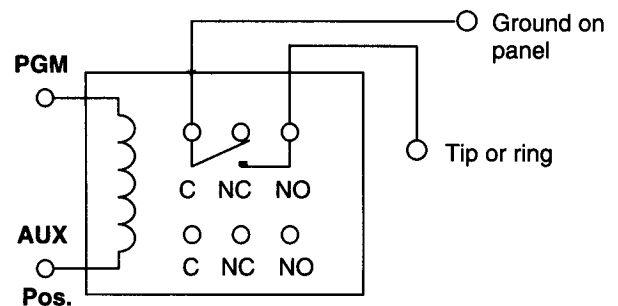

Note: The panel must be attached to either earth or cold water pipe ground for proper ground start operation.

Note: When using a RBSN-TTL relay module. Tie the TRG terminal on the RBSN-TTL module to the positive voltage terminal 7 of the panel and use it just like a RBSN module.

UNDERWRITERS LABORATORIES
COMPLIANCE VERIFICATION CHART

GENESYS 824

When programming the Genesys 824, the following programs must be maintained to meet minimum UL requirements for Household Burglar Systems, and/or commercial burglar alarm systems, and police connect.

Exit Time not to exceed 60 seconds.

Entrance Time not to exceed 45 seconds including pre-alarm delay.

Loop Response not to exceed 1 second.

Bell and/or Siren - 4 minutes minimum (to meet UL residential Burg and Fire)

Bell and/or Siren - 15 minutes minimum (to meet UL commercial Burglar Alarm and Police Connect)

Burglar Alarm Loops must alarm in an Open or Shorted condition.

Low Battery must be programmed to report.

Two (2) separate telephone numbers must be programmed (Receiver 1 and Receiver 2)

Close Ringback - Program "YES".

SMOKE DETECTORS

To reset Smoke Detector, enter four digit PIN.

SMOKE DETECTOR PLACEMENT - Reprinted from NFPA Standard 74

B-2 Smoke Detection.

B-2.1 Where to Locate the Required Smoke Detectors.

B-2.1.1 The major threat from fire in a family living unit is at night when everyone is asleep. The principal threat to persons in sleeping areas comes from fires in the remainder of the unit; therefore, smoke detector(s) are best located between the bedroom areas and the rest of the unit. In units with only one bedroom area on one floor, the smoke detector should be located as shown in Figure B-2.1.1.

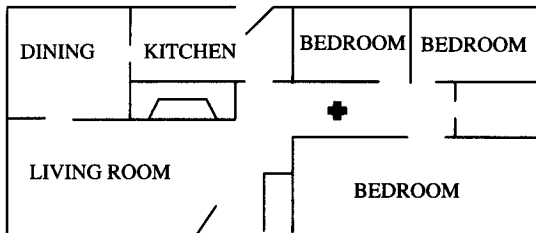

Figure B-2.1.1 A smoke detector (indicated by cross) should be located between the sleeping area and the rest of the family living unit.

B-2.1.2 In family living units with more than one bedroom area or with bedrooms on more than one floor, more than one smoke detector will be needed, as shown in Figure B-2.1.2

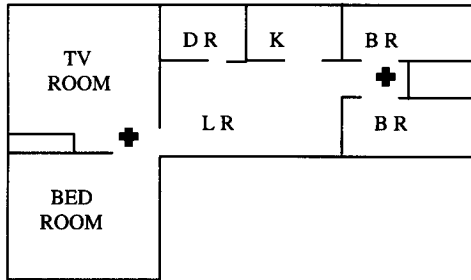

Figure B-2.1.2 In family living units with more than one sleeping area, a smoke detector (indicated by cross) should be provided to protect each.

B-2.1.3 In addition to smoke detectors outside of the sleeping areas, this standard requires the installation of a smoke detector on each additional story of the family living unit, including the basement. These installations are shown in Figure B-2.1.3. The living area smoke detector should be installed in the living room and/or near the stairway to the upper level. The basement smoke detector should be installed in close proximity to the stairway leading to the floor above. If installed on an open-joisted ceiling, the detector should be placed on the bottom of the joists. The detector should be positioned relative to the stairway so as to intercept smoke coming from a fire in the basement before the smoke enters the stairway.

B-2.2 Are More Smoke Detectors Desirable? The location of the required smoke detectors does not provide adequate protection for the occupants from a fire starting within their bedrooms, nor do the required smoke detectors provide reliable early warning protection for those areas separated by a door from the areas protected by the required smoke detectors. For these reasons, it is recommended that the householder consider the use of additional smoke detectors for those areas for increased protection. The additional areas include: basement, bedrooms, dining room, furnace room, utility room, and hallways not protected by required smoke detectors. The installation of smoke detectors in kitchens, attics (finished or unfinished), or in garages is not normally recommended as these locations occasionally experience conditions which may result in improper operation.

B-2.3 Smoke Detector Mounting - "Dead" Air Space.

B-2.3.1 The smoke from a fire generally rises to the ceiling, spreads out across the ceiling surface and begin to bank down from the ceiling. The corner where the ceiling and wall meet is an air space into which the smoke may have difficulty penetrating. In most fires, this "dead" air space measures about 4 in. (0.1m) along the ceiling from the corner and about 4 in. (0.1m) down the wall as shown in Figure B-3.2.1. Detectors should not be placed in this "dead" air space.

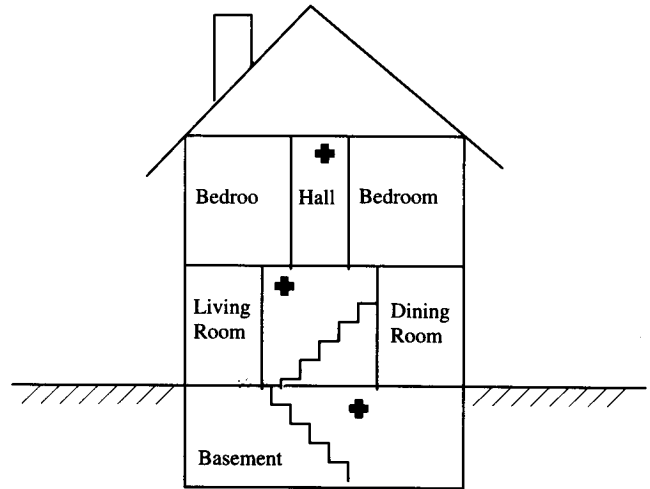

Figure B-2.1.3 A smoke detector (indicated by cross) should be located on each story.

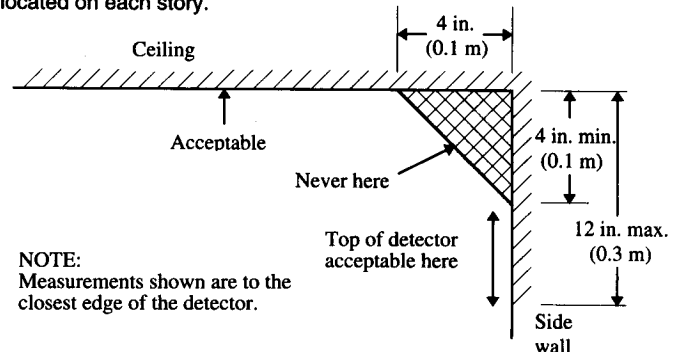

Figure B-3.2.1 Example of proper mounting for detectors.

UL Verification Information - Genesys 824 - continued:

FOR GRADE A LOCAL MERCANTILE INSTALLATIONS

The minimum requirements to form a Listed Grade A Local system includes:

Low Battery alarm annunciation (unless dialer is used to transmit a low battery message).

CURRENT RATING CHART

CONTROL (G-824)	=	100 mA
KEYPAD (G-KP)	=	24 mA
FIRE MODULE (G-FM)	=	50 mA
EXPANSION BOARD (G-EX)	=	29 mA

BATTERY CALCULATIONS

EXAMPLE:

4 HOUR STANDBY PLUS 15 MINUTE BELL RINGING:

G-824 (w/1 keypad)	=	124 mA x 4 hours	=	.496 AH
Bell	=	$\frac{125 \text{ mA} \times 15 \text{ minutes}}{60}$	=	.031 AH
Control (w/keypad)	=	$\frac{124 \text{ mA} \times 15 \text{ minutes}}{60}$	=	.031 AH
			TOTAL =	.558 AH

WORKSHEET:

Control (G-824)	100 mA	x	_____	Hours	=	_____	AH
Keypad (G-824)	24 mA	x	_____	Hrs x # of KP's	=	_____	AH
Bell	125 mA	x	15 minutes		=	<u>.031</u>	AH
FM	50 mA	x	_____	Hours	=	_____	AH
Control (while bell ringing)	100 mA	x	15 minutes		=	<u>.025</u>	AH
Switched AUX Power	_____ mA	x	_____	Hours	=	_____	AH
Continuous AUX Power	_____ mA	x	_____	Hours	=	_____	AH
			TOTAL	=	_____	AH	

BATTERY PART NUMBERS

RB-12151.5 AH	(minimum for 4 hours)
RB-12262.6 AH	(alternate for 4 hours)
RB-12656.5 AH	(one required for 24 hours)

DECIMAL TO HEXADECIMAL CONVERSION CHART

Chart 1

DEC HEX	DEC HEX	DEC HEX	DEC HEX	DEC HEX	DEC HEX	DEC HEX
000 00	040 28	080 50	120 78	160 A0	200 C8	240 F0
001 01	041 29	081 51	121 79	161 A1	201 C9	241 F1
002 02	041 2A	082 52	122 7A	162 A2	202 CA	242 F2
003 03	043 2B	083 53	123 7B	163 A3	203 CB	243 F3
004 04	044 2C	084 54	124 7C	164 A4	204 CC	244 F4
005 05	045 2D	085 55	125 7D	165 A5	205 CD	245 F5
006 06	046 2E	086 56	126 7E	166 A6	206 CE	246 F6
007 07	047 2F	087 57	127 7F	167 A7	207 CF	247 F7
008 08	048 30	088 58	128 80	168 A8	208 D0	248 F8
009 09	049 31	089 59	129 81	169 A9	209 D1	249 F9
101 0A	050 32	090 5A	130 82	170 AA	210 D2	250 FA
011 0B	051 33	091 5B	131 83	171 AB	211 D3	251 FB
012 0C	052 34	092 5C	132 84	172 AC	212 D4	252 FC
013 0D	053 35	093 5D	133 85	173 AD	213 D5	253 FD
014 0E	054 36	094 5E	134 86	174 AE	214 D6	254 FE
015 0F	055 37	095 5F	135 87	175 AF	215 D7	255 FF
016 10	056 38	096 60	136 88	176 B0	216 D8	
017 11	057 39	097 61	137 89	177 B1	217 D9	
018 12	058 3A	098 62	138 8A	178 B2	218 DA	
019 13	059 3B	099 63	139 8B	179 B3	219 DB	
020 14	060 3C	100 64	140 8C	180 B4	220 DC	
021 15	061 3D	101 65	141 8D	181 B5	221 DD	
022 16	062 3E	102 66	142 8E	182 B6	222 DE	
023 17	063 3F	103 67	143 8F	183 B7	223 DF	
024 18	064 40	104 68	144 90	184 B8	224 E0	
025 19	065 41	105 69	145 91	185 B9	225 E1	
026 1A	066 42	106 6A	146 92	186 BA	226 E2	
027 1B	067 43	107 6B	147 93	187 BB	227 E3	
028 1C	068 44	108 6C	148 94	188 BC	228 E4	
029 1D	069 45	109 6D	149 95	189 BD	229 E5	
030 1E	070 46	110 6E	150 96	190 BE	230 E6	
031 1F	071 47	111 6F	151 97	191 BF	231 E7	
032 20	072 48	112 70	152 98	192 C0	232 E8	
033 21	073 49	113 71	153 99	193 C1	233 E9	
034 22	074 4A	114 72	154 9A	194 C2	234 EA	
035 23	075 4B	115 73	155 9B	195 C3	235 EB	
036 24	076 4C	116 74	156 9C	196 C4	236 EC	
037 25	077 4D	117 75	157 9D	197 C5	237 ED	
038 26	078 4E	118 76	158 9E	198 C6	238 EE	
039 27	079 4F	119 77	159 9F	199 C7	239 EF	

THIS CHART CONVERTS DECIMAL VALUES FROM 000 TO 255 INTO 2 DIGIT HEXADECIMAL EQUIVALENTS.